

J. HARTNESS.

STOCK FEEDING DEVICE FOR SCREW MACHINES.

No. 441,411.

Patented Nov. 25, 1890.

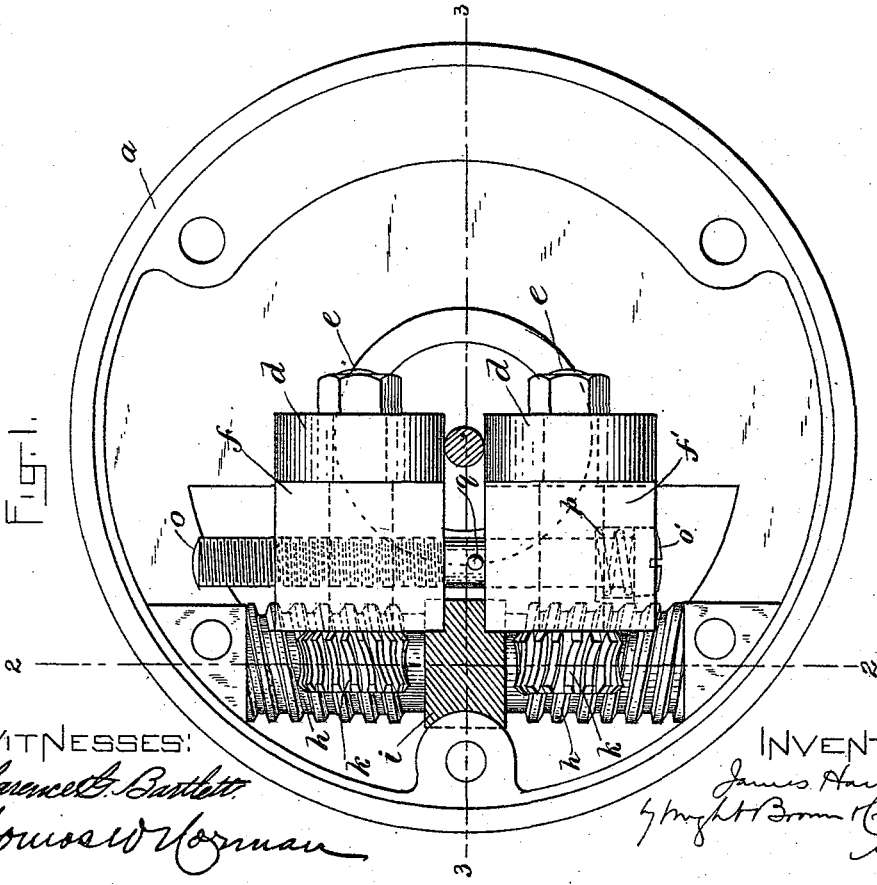
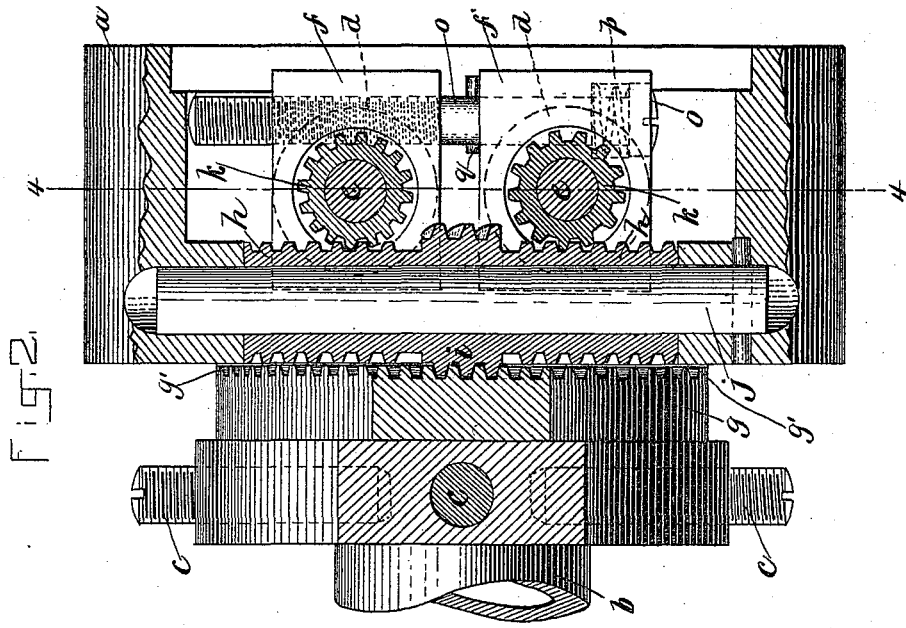

WITNESSES:
Charcett Bartlett
Thomas W. Hornum

INVENTOR:
James Hartness
Wm. H. Brown
Atty.

J. HARTNESS.

STOCK FEEDING DEVICE FOR SCREW MACHINES.

No. 441,411.

Patented Nov. 25, 1890.

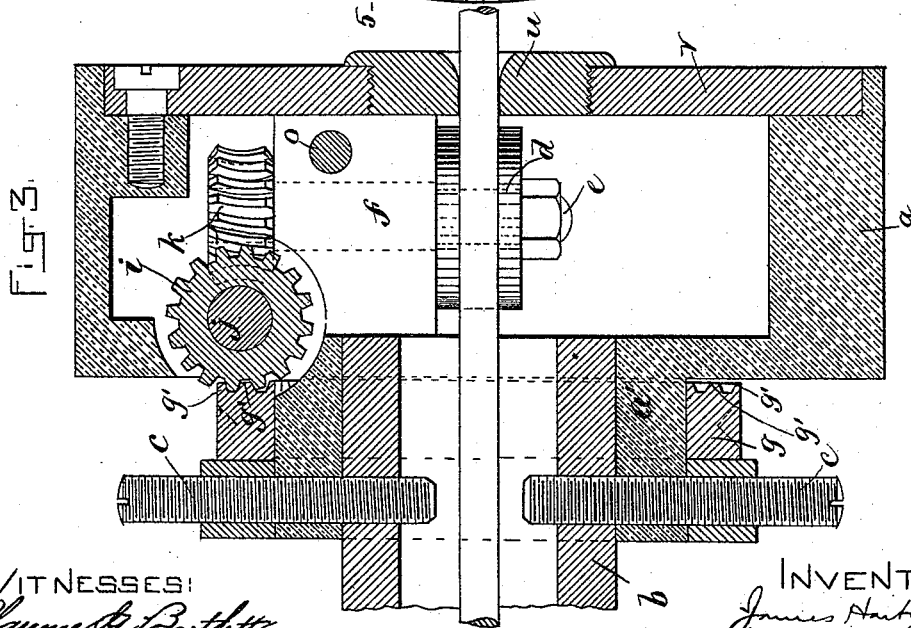
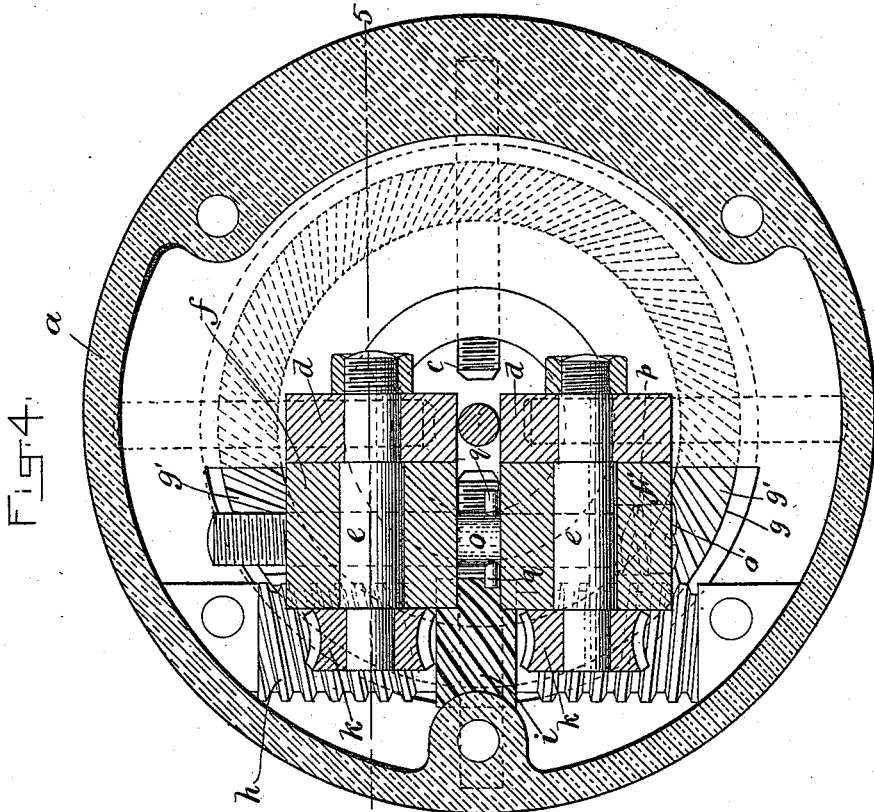

WITNESSES:

Clarence C. Partridge
Howard W. Johnson

INVENTOR:

James Hartness
 by *Wm H. Brown* Attorney

J. HARTNESS.

STOCK FEEDING DEVICE FOR SCREW MACHINES.

No. 441,411.

Patented Nov. 25, 1890.

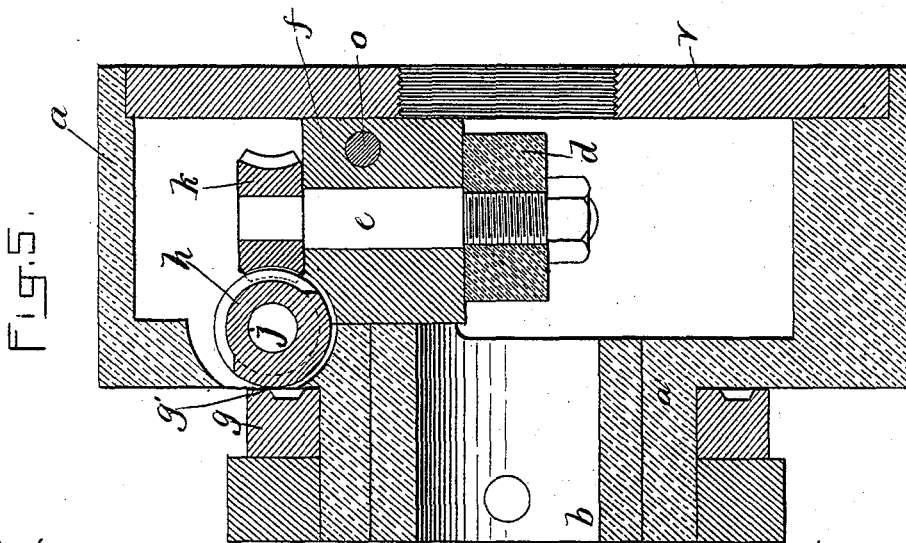
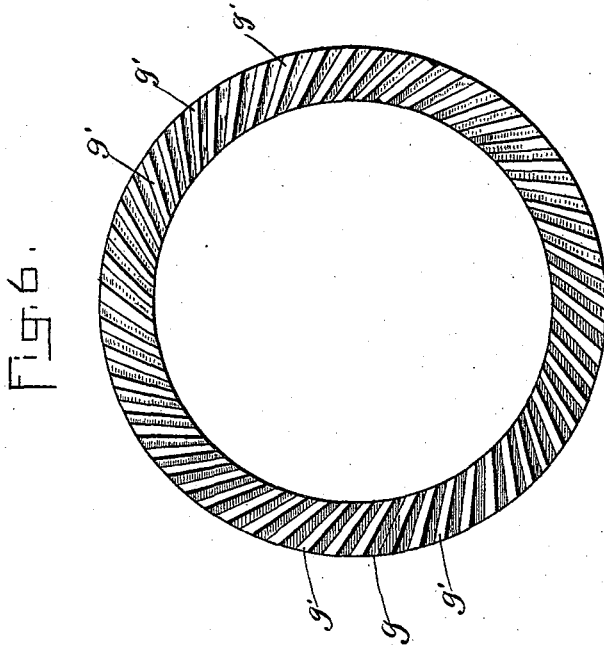

WITNESSES:

Charles S. Burtlett
Thomas W. Forman

INVENTOR:

James Hartness
By Wright Brown Forsley
 Atty.

UNITED STATES PATENT OFFICE.

JAMES HARTNESS, OF SPRINGFIELD, VERMONT.

STOCK-FEEDING DEVICE FOR SCREW-MACHINES.

SPECIFICATION forming part of Letters Patent No. 441,411, dated November 25, 1890.

Application filed August 18, 1890. Serial No. 362,314. (No model.)

To all whom it may concern:

Be it known that I, JAMES HARTNESS, of Springfield, in the county of Windsor and State of Vermont, have invented certain new and useful Improvements in Stock-Feeding Mechanism for Screw-Machines, of which the following is a specification.

This invention relates to means for feeding rapidly-rotating bars, rods, or wires of metal through the holding-chucks of screw-machines by the use of feed-rolls which are revolved about the rotating bars, &c., and are also rotated on their own axes while revolving, as shown in Letters Patent of the United States No. 425,377, of date April 8, 1890.

The invention has for its object, first, to provide simple, strong, and effective means for supporting the feed-rolls within the rotating head which contains them; secondly, to provide improved means for simultaneously rotating said rolls while they are revolving about the axis of the head, and, thirdly, to provide improved means for adjusting the rolls to the size of the said bars, rods, or wires.

To these ends the invention consists in the improvements which I will now proceed to describe and claim.

In the accompanying drawings, forming a part of this specification, Figure 1 represents a front end elevation of the rotary head, the feed-rolls therein, and the feed-roll supporting and operating devices embodying my improvements, the front plate of said head being removed to show more clearly the internal parts. Fig. 2 represents a section on line 2 2, Fig. 1. Fig. 3 represents a section on line 3 3, Fig. 1. Fig. 4 represents a section on line 4 4, Fig. 2. Fig. 5 represents a section on line 5 5, Fig. 4. Fig. 6 represents a side view of the annular worm or scroll, hereinafter referred to.

The same letters of reference indicate the same parts in all the figures.

In the drawings, *a* represents a head or holder, which may be affixed to the tubular spindle *b* of a lathe by any suitable means.

d d represent the feed-rolls which feed the stock, or, in other words, the rod or wire from which screws or other like articles are made by the mechanism with which the machine to which my improved feeding devices are applied is provided. The shafts *e e*, to which

said feed-rolls are attached, are journaled in blocks *f f'*, which are adapted to slide on suitable guides or ways in the head *a*, the movement of said blocks being such that the feed-rolls, which are arranged at opposite sides of the axial center of the head, can move radially, and thus approach and recede from each other to accommodate stock of any diameter within the capacity of the machine.

g represents a scroll or worm, which is a ring fitted to rotate on the exterior of the neck *a'* of the head, said ring being provided on one side with teeth *g'*, which are cut tangentially, each tooth being a tangent of a circle of lesser diameter than the interior of the ring, as shown in Fig. 6.

h h represent right and left hand worms, which are rigidly connected, and *i* represents a worm wheel or gear, which is located between said worms and is rigidly connected therewith, said worms and wheels being here shown as all formed in one piece and adapted to rotate on a stud or bearing *j*, affixed to the head *a*. The said worm-wheel *i* has its teeth formed to engage the tangential teeth *g'* of the scroll or worm *g*, while the right and left worms *h h* engage corresponding worm-wheels *k k*, affixed to the shafts of the feed-rolls. The said worm-gear *i*, worms *h h*, and worm-gears *k k* constitute connections between the feed-roll shafts and the annular worm or scroll *g*, whereby the feed-roll shafts may be simultaneously rotated in opposite directions when the head *a* is rotated and the annular worm or scroll is held stationary, the worm or scroll when thus held causing the gear *i* and worms *h h* to rotate on their common axis while they are being revolved about the center of the head by the rotation of the latter, while the worms impart rotary motion to the feed-roll shafts, each feed-roll being thus given a planetary motion—viz., a revolution about the center of the head by the rotation of the latter—and a rotary movement on its own axis by the described connection with the annular worm or scroll. It will also be seen that the connection between the annular worm or scroll and the feed-roll shafts is equally operative under all adjustments of the feed-rolls, so that the rolls are rotated in the manner described in any of the positions to which they may be adjusted.

The said worm-gear *i*, worms *h h*, and worm-gears *k k* constitute connections between the feed-roll shafts and the annular worm or scroll *g*, whereby the feed-roll shafts may be simultaneously rotated in opposite directions when the head *a* is rotated and the annular worm or scroll is held stationary, the worm or scroll when thus held causing the gear *i* and worms *h h* to rotate on their common axis while they are being revolved about the center of the head by the rotation of the latter, while the worms impart rotary motion to the feed-roll shafts, each feed-roll being thus given a planetary motion—viz., a revolution about the center of the head by the rotation of the latter—and a rotary movement on its own axis by the described connection with the annular worm or scroll. It will also be seen that the connection between the annular worm or scroll and the feed-roll shafts is equally operative under all adjustments of the feed-rolls, so that the rolls are rotated in the manner described in any of the positions to which they may be adjusted.

The said worm-gear *i*, worms *h h*, and worm-gears *k k* constitute connections between the feed-roll shafts and the annular worm or scroll *g*, whereby the feed-roll shafts may be simultaneously rotated in opposite directions when the head *a* is rotated and the annular worm or scroll is held stationary, the worm or scroll when thus held causing the gear *i* and worms *h h* to rotate on their common axis while they are being revolved about the center of the head by the rotation of the latter, while the worms impart rotary motion to the feed-roll shafts, each feed-roll being thus given a planetary motion—viz., a revolution about the center of the head by the rotation of the latter—and a rotary movement on its own axis by the described connection with the annular worm or scroll. It will also be seen that the connection between the annular worm or scroll and the feed-roll shafts is equally operative under all adjustments of the feed-rolls, so that the rolls are rotated in the manner described in any of the positions to which they may be adjusted.

When the annular worm or scroll is left loose or idle and permitted to rotate with the head, there will be no independent rotation of the feed-rolls, and they will simply revolve idly about the center of the head without feeding the stock.

The annular worm may be made operative to cause the above-described rotation of the feed-rolls in any suitable way. For example, it may be prevented from rotating when it is desired to cause the feed-rolls to operate by means of a friction band or brake applied to the periphery of the ring which composes the annular worm in the same manner that the loose gear *m* (shown in my patent above referred to) is held to operate the feed-rolls shown in that patent. I have not illustrated said band and the devices that operate it in the present case, because the application of the devices shown in my former patent to the annular worm *g* will be perfectly obvious. My invention is not limited, however, to the friction-band as the means for holding the annular worm *g* nor to a normally-loose worm and devices for holding the same to make it inoperative. The same result may be produced by continuously or permanently holding the annular worm so that it cannot rotate and moving the same laterally into and out of engagement with the worm-gear *i* to make it operative and inoperative.

I do not limit myself to the devices here shown for imparting rotary motion to the feed-rolls while they are revolving about the center of the chuck, but may use any other suitable means adapted to operate the radially-adjustable feed-rolls in any of the positions to which they may be adjusted, the feature of my invention to which I attach the most importance being the feed-rolls and the feed-roll carrying-blocks adjustable radially on guides or ways in the rotary head.

For adjusting the feed-rolls to the diameter of the stock I have here shown a bolt *o*, which is screw-threaded at one end and engaged at its screw-threaded portion with the block *f*. The unthreaded portion of the bolt passes through the other block *f'*, and is provided with a slotted head *o'*, which permits the bolt to be turned by a suitable tool. A spring *p*, interposed between the head of the bolt and the bottom of an enlargement of the socket in the block *f'*, presses said block against the ends of a pin *q*, which is inserted in the bolt *o* between the blocks. The rotation of the bolt in one direction causes it to increase the distance between the blocks and feed-rolls, while a rotation of said bolt in the opposite direction decreases the distance between the blocks and feed-rolls.

The feed-rolls *d d* do not act to center the stock in the head, the stock being held central by a centering-bushing *u*, which is removably inserted in the face-plate *v* of the head *a*, and has an orifice formed to closely fit the stock, said orifice being at the axial center of the head. The bushing *u* may be

assisted, when heavy stock is used, by the centering-screws *c c* in the neck of the head *a*. A separate bushing is employed for each size of stock, the bushing being externally screw-threaded and screwed into an internally-threaded opening in the face-plate *v*.

The feed-rolls and their supporting-blocks are loosely mounted in the head and conform to the position in which the stock is held by the centering devices.

I claim—

1. The combination of a rotary head or holder, a plurality of feed-rolls within the same arranged to bear simultaneously on the stock, which occupies the axial center of the head, blocks adapted to slide radially in the head and supporting the shafts of the feed-rolls, and means for simultaneously rotating said rolls, as set forth.

2. The combination of a rotary head or holder, a normally-loose annular worm or scroll concentric with the axis of the head, a plurality of feed-rolls in the head arranged to bear simultaneously on the stock, blocks adapted to slide radially in the head and supporting the feed-roll shafts, and connections between the said feed-roll shafts and annular worm, whereby said rolls may be simultaneously rotated, as set forth.

3. The combination of the rotary head or holder, a plurality of feed-rolls within the same arranged to bear simultaneously on the stock, which occupies the axial center of the head, blocks adapted to slide radially in the head and supporting the shafts of the feed-rolls, and adjusting devices whereby said blocks may be moved toward or from each other to decrease or increase the distance between the feed-rolls, as set forth.

4. The combination of a rotary head or holder, a normally-loose annular worm or scroll concentric with the axis of the head, a plurality of feed-rolls in the head arranged to bear simultaneously on the stock, blocks adapted to slide radially in the head and supporting the feed-roll shafts, the worm-gear, and right and left gears connected to rotate together in said head, said worm-gear meshing with the annular worm or scroll, and the worm-gears on the feed-roll shafts meshing with the said right and left worms, as set forth.

5. The combination of a rotary head or holder, a normally-loose annular worm or scroll concentric with the axis of the head, a plurality of feed-rolls in the head arranged to bear simultaneously on the stock, blocks adapted to slide radially in the head and supporting the feed-roll shafts, the worm-gear, and right and left gears connected to rotate together in said head, said worm-gear meshing with the annular worm or scroll, the worm-gears on the feed-roll shafts meshing with the said right and left worms, and devices for adjusting said blocks to vary the distance between the feed-rolls, as set forth.

6. The combination of the rotary head, the

blocks adapted to slide radially in said head, the shafts journaled in said blocks, the feed-rolls attached to the shafts, means for simultaneously rotating said shafts and rolls, and the block-adjusting devices comprising the headed bolt having a screw-thread connection with one block and a loose connection with the other, one or more projections on said bolt between the blocks, and a spring interposed between the head of the bolt and the block adjacent to said head, as set forth.

7. The combination of the rotary head, the blocks adapted to slide radially in the head and loosely mounted therein, the shafts jour-

naled in said blocks, the feed-rolls attached to the shafts, means for simultaneously rotating said shafts and rolls, and stock-centering devices on the head, whereby the stock is centrally held, the feed-rolls conforming to the position of the stock, as set forth.

In testimony whereof I have signed my name to this specification, in the presence of two subscribing witnesses, this 28th day of July, A. D. 1890.

JAMES HARTNESS.

Witnesses:

E. R. FELLOWS,
T. CHYNOWETH.